

# Orion® SpaceProbe™ II 76mm Equatorial Reflector

#10274

## Français

❶ Pour obtenir le manuel d'utilisation complet, veuillez vous rendre sur le site Web **OrionTelescopes.eu/fr** et saisir la référence du produit dans la barre de recherche.

Mon compte • Suivi de commande • Chat • Aide | Français EUR  
 Connexion  
 Entrez le mot clé ou le numéro du produit Recherche

❷ Cliquez ensuite sur le lien du manuel d'utilisation du produit sur la page de description du produit.

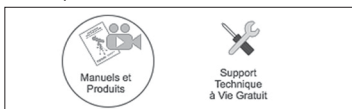

## Deutsche

❶ Wenn Sie das vollständige Handbuch einsehen möchten, wechseln Sie zu **OrionTelescopes.de**, und geben Sie in der Suchleiste die Artikelnummer der Orion-Kamera ein.

Mein Konto • Bestellstatus • Chat • Hilfe | Deutsch EUR  
 Anmelden  
 Geben Sie das Stichwort oder die Produktnummer ein. Suchen

❷ Klicken Sie anschließend auf der Seite mit den Produktdetails auf den Link des entsprechenden Produkthandbuchs.



## Español

❶ Para ver el manual completo, visite **OrionTelescopes.eu** y escriba el número de artículo del producto en la barra de búsqueda.

My Account • Order Status • Chat • Help | English EUR  
 Sign In  
 Enter keyword or product number Search

❷ A continuación, haga clic en el enlace al manual del producto de la página de detalle del producto.



Corporate Offices: 89 Hangar Way, Watsonville CA 95076 - USA  
 Toll Free USA & Canada: (800) 447-1001  
 International: +1(831) 763-7000  
 Customer Support: support@telescope.com

Copyright © 2020 Orion Telescopes & Binoculars. All Rights Reserved. No part of this product instruction or any of its contents may be reproduced, copied, modified or adapted, without the prior written consent of Orion Telescopes & Binoculars.

*Congratulations on your purchase of an Orion telescope. Your new SpaceProbe II 76mm Equatorial Reflector is a terrific starter instrument for exploring the exotic wonders of the night sky. Designed to be lightweight and easy to use, it will provide many hours of enjoyment for the whole family.*

If you have never owned a telescope before, we would like to welcome you to amateur astronomy. Take some time to familiarize yourself with the night sky. Learn to recognize the patterns of stars in the major constellations. With a little practice, a little patience, and a reasonably dark sky away from city lights, you'll find your telescope to be a never-ending source of wonder, exploration, and relaxation.

These instructions will help you set up, properly use, and care for your telescope. Please read them over thoroughly before getting started.

## Table of Contents

1. Parts . . . . .	2
2. Assembly . . . . .	2
3. Preparing the Telescope for Operation . . . . .	5
4. Understanding and Using the Equatorial Mount . . . . .	8
5. Astronomical Observing . . . . .	12
6. Useful Optional Accessories . . . . .	14
7. Aligning the Mirrors (Collimation) . . . . .	14
8. Telescope Care and Maintenance . . . . .	15
9. Specifications . . . . .	16

N – Counterweight lock knob	1
O – Counterweight	1
P – Slow-motion cables	2
Q – Mounting platform	1
R – Tube ring	1
S – Tube ring mounting hardware	6
T – Screwdriver tool	1
U – Optical tube assembly	1
V – Red dot finder scope	1
W – 25mm Kellner eyepiece	1
X – 10mm Kellner eyepiece	1
Y – Dust cover	1
Z – Allen wrench (not shown)	1

**WARNING:** *Never look directly at the Sun through your telescope—even for an instant—without a professionally made solar filter that completely covers the front of the instrument, or permanent eye damage could result. Young children should use this telescope only with adult supervision.*

## 1. Parts

Remove and identify all parts, using the list below and **Figure 1** for reference.

Part	Qty
A – Tripod legs	3
B – Hex-head tripod mounting bolts	3
C – Washers (5/8")	3
D – Wing nuts (large)	3
E – Leg lock thumbscrew	3
F – Accessory tray	1
G – Screws	3
H – Washers (3/8")	3
I – Wing nuts (small)	3
J – Equatorial mount	1
K – Azimuth lock knob (and washer)	1
L – Latitude adjustment bolt	1
M – Counterweight shaft	1

## 2. Assembly

Refer to **Figures 1** and **2** and the parts list at left for identification of specific parts during assembly.

1. Attach the three aluminum tripod legs (A) to the mounting platform (Q) (**Figure 3a**) with the three hinged leg braces facing inward. Three hex-head bolts (B) each about 3" long, with 5/8" washers (C) and wing nuts (D), are provided for this purpose. Note that the bolts should be inserted from the side of the leg that has the hex-shaped hole, so that the bolt head seats in the hex-shaped hole (**Figure 3b**). The washer then the wing nut are placed on the opposite side on the exposed end of the bolt.
2. Attach a leg lock thumbscrew (E) to each leg as shown (**Figure 4**). Extend the sliding inner portion of the adjustable-height tripod leg to the desired length for all three legs. Lock in place by tightening the leg lock thumbscrews. Do not over-tighten the leg lock thumbscrews or you may damage the collar they are attached to.
3. Now stand the tripod upright, spreading the legs evenly apart so the accessory tray can be positioned to attach to the three leg braces.
4. Attach the accessory tray (F) to the leg brace supports (**Figure 5**) with the three short screws (G), small (3/8")

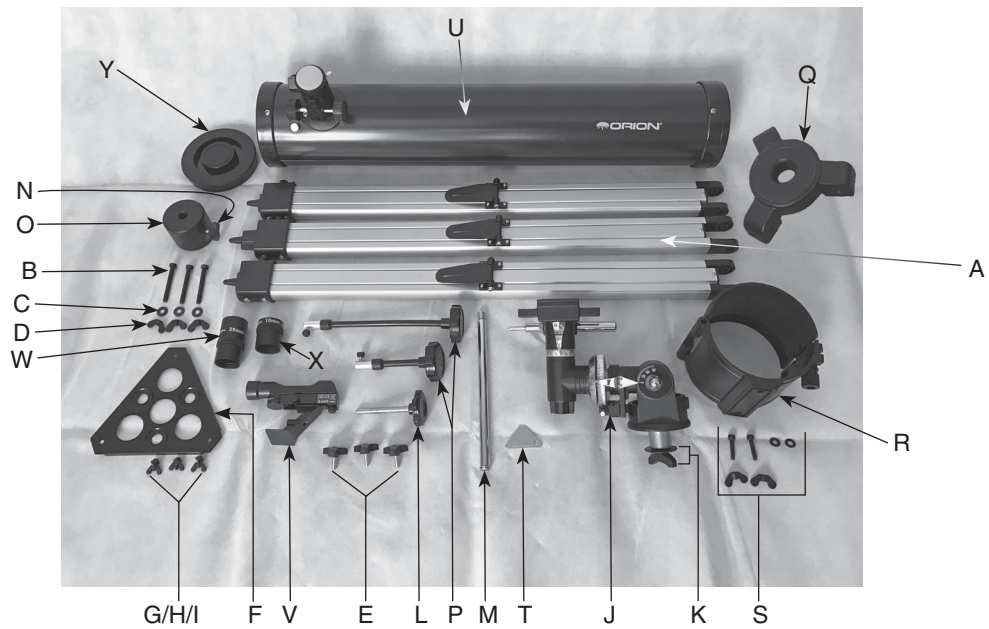

**Figure 1.** The parts of the SpaceProbe II 76mm EQ telescope.

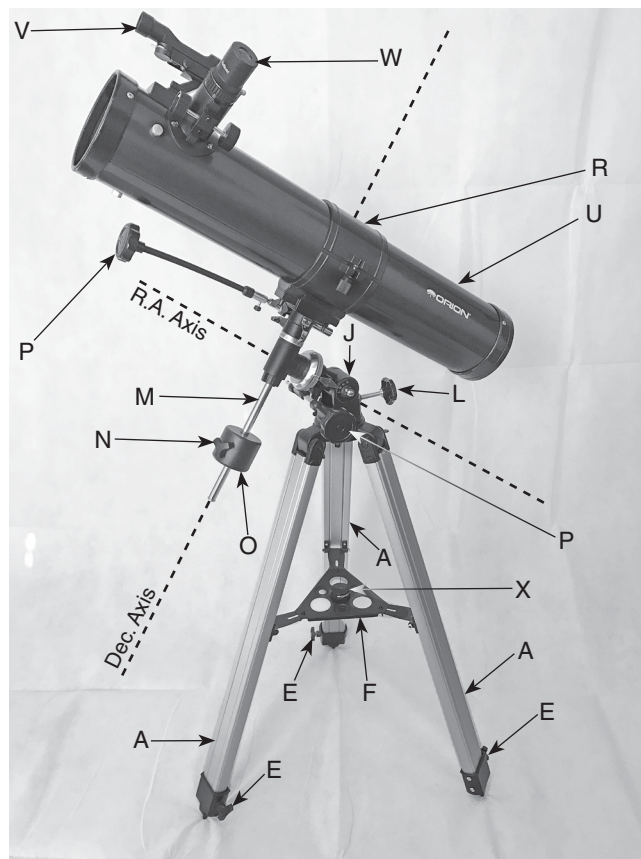

**Figure 2.** The SpaceProbe II 76 EQ telescope fully assembled with key parts identified.

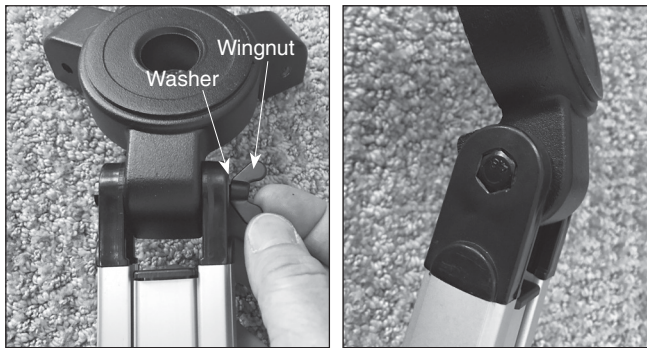
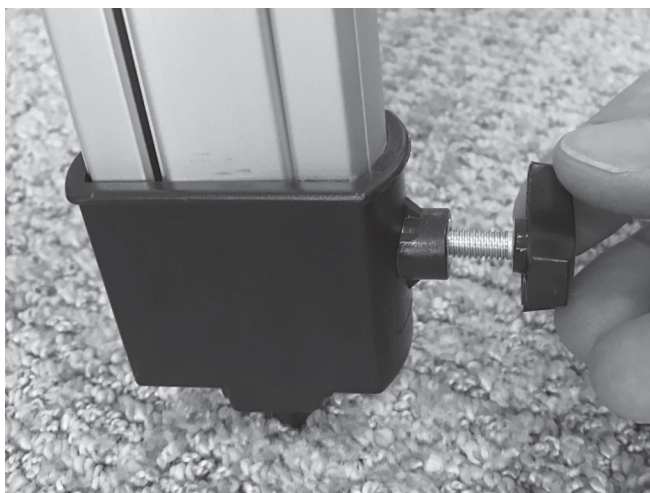

**Figure 3.** a) Attach the three tripod legs to the mount platform, b) making sure the bolt's hex-shaped head seats in the hex-shaped recess of the tripod leg.

washers (H), and small wing nuts (I) provided. Place a washer on the screw. Then place the accessory tray on top of one of the leg braces so that the mounting screw passes through the hole at one of the corners of the accessory tray, and through the slot in the leg brace. Then place another small washer on the screw and thread on and tighten the wing nut. Repeat this procedure until the tray is attached to all three leg braces.

The tripod is now fully assembled (**Figure 6**). Next you will install the equatorial mount onto the tripod.

5. Locate the equatorial (EQ) mount (J) and place its base into the hole in the center of the mounting platform (Q) (**Figure 7a**). Then secure it in place with the azimuth lock knob and washer (K) (**Figure 7b**).
6. Thread the latitude adjustment bolt (L) into the threaded socket (**Figure 8**) until it contacts metal inside the housing.
7. Next, thread the counterweight shaft (M) into the base of the Declination axis of the mount (**Figure 9**).
8. Thread the counterweight lock knob (N) into the counterweight (O) a few turns.

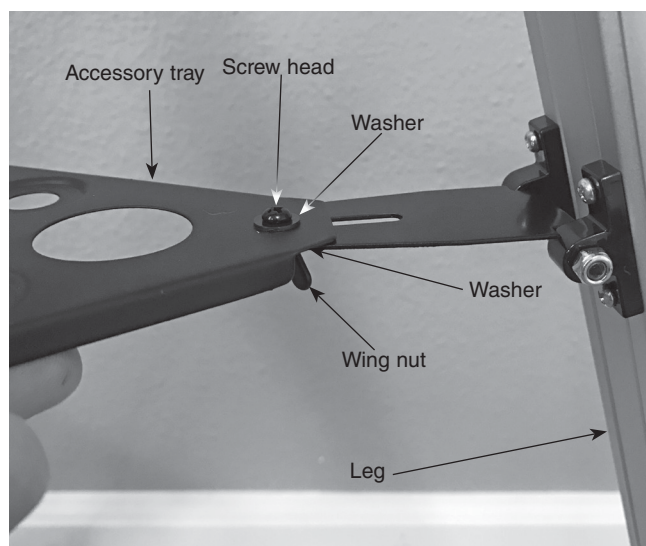

**Figure 4.** Thread a leg lock thumbscrew onto each tripod leg as shown, being careful not to overtighten.

9. To slide the counterweight onto the counterweight shaft, first remove the Philips screw and washer from the end of the shaft. You can use the screwdriver tool (T) for this. Make sure the counterweight lock knob (N) is loosened enough so that the metal pin inside the counterweight is clear of the shaft hole. Slide the counterweight about 2 inches from the bottom of the counterweight shaft and secure it in place with the lock knob (**Figure 10**). Then replace the washer and screw at the end of the counterweight shaft.
10. Attach the slow motion cables (P) to the gear shafts as shown in **Figure 11**. The longer cable should be attached to the declination gear shaft; the shorter cable to the right ascension gear shaft. Orient the cable so that the thumb-screw seats in the groove of the gear shaft, as shown in **Figure 12**, then firmly tighten the thumbscrew. If there is a small rubber ball on the end of the shaft, you will have to remove it in order to attach the cable. Also note that, depending on your preference, you can attach the cable to either the left or right side of the right ascension gear shaft.

Now the mount is properly attached to the tripod and outfitted for use (**Figure 13**). Next, you'll attach the tube ring and optical tube to the EQ mount.

11. To attach the tube ring (R), set the bottom of the ring into the EQ head's saddle and bolt it on with the two supplied socket head bolts, washers, and wing nuts (S) as shown in **Figure 14**. You can use the supplied Allen wrench (Z, not shown in Fig. 1) to help tighten the bolt while holding the wing nut. Do not overtighten!
12. Then lay the telescope optical tube (U) into the open tube ring. Close the tube ring around the tube and tighten the tube ring clamp knob. The telescope should now look like **Figure 15**.
13. To attach the red dot finder scope (V) to the optical tube, orient the finder scope as shown in **Figure 16** and slide the bracket foot into the finder scope base until it clicks.



**Figure 5.** Attach the accessory tray to each of the tripod three leg brace supports using the provided hardware.



**Figure 6.** The fully assembled tripod.

(To remove the finder scope, press the small tab at the back of the base and slide the bracket out.)

14. Insert the 25mm eyepiece (W) into the focuser and secure it by lightly tightening the thumbscrew (**Figure 17**).

The telescope is now completely assembled! Before it can be effectively used, however, there are a couple of things to do to prepare the telescope for operation.

### 3. Preparing the Telescope for Operation

#### Aligning and Using the Red Dot Finder Scope

The included red dot finder scope (**Figure 18**) makes pointing your telescope almost as easy as pointing your finger! It's a non-magnifying aiming device that superimposes a tiny LED red dot on the sky, showing exactly where the telescope is pointed. It permits easy object targeting prior to observation in the higher-power main telescope.

Before you can use the red dot finder scope, you must remove the small plastic tab sticking out from the battery compartment (**Figure 18**). Doing so will allow the pre-installed 3V CR-2032 button cell battery to make contact with the finder scope's electronic circuitry to power the finder's red LED illuminator. The tab can then be discarded.

To use the red dot finder scope properly, it must be aligned with the main telescope. This is easiest to do during daylight hours, before observing at night. Follow this procedure:

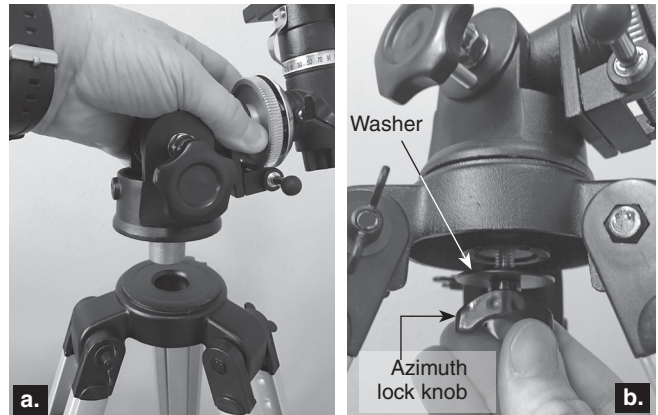
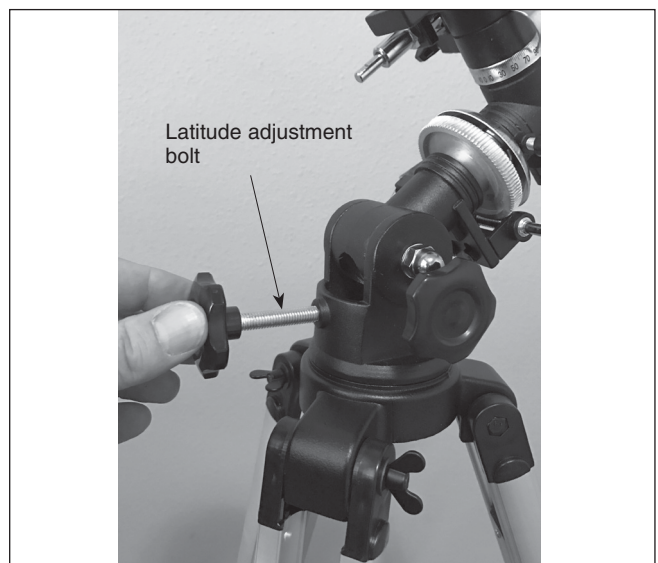

**Figure 7. a)** Install the equatorial mount onto the tripod mount platform, then **b)** secure it from the underside with azimuth lock knob.

1. First, remove the dust cap (Y) from the front of the telescope.
2. With the 25mm eyepiece already in place from step 14 above, point the telescope at a well-defined land target (e.g., the top of a telephone pole) that's at least a quarter mile away. Center the target in the eyepiece by turning the slow-motion cables as needed to point the telescope. For larger telescope movement, release the RA and Dec axis lock knobs (**Figure 19**) and move the telescope tube by hand to the approximate location, then retighten the lock knobs and make finer pointing adjustments with the slow motion cables.

**Note:** The image in the telescope will appear rotated, often upside down. This is normal for reflector telescopes and is why reflectors are not recommended for daytime terrestrial viewing.

3. Now that a distant target is centered in the main telescope's eyepiece, turn on the red dot finder scope by slid-



**Figure 8.** Screw in the latitude adjustment bolt.

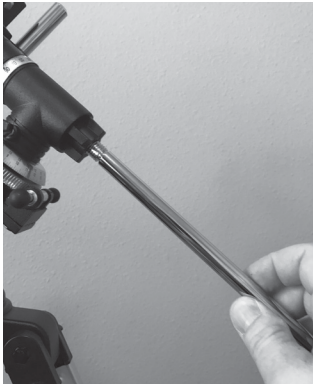

**Figure 9.** Thread the counterweight shaft into the declination housing.

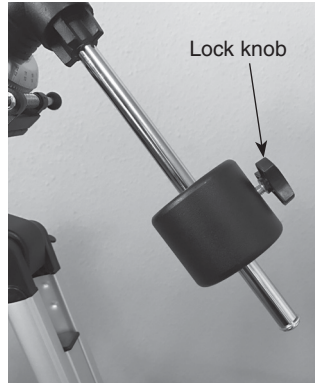

**Figure 10.** The counterweight, installed.

ing the power switch to ON (refer to **Figure 18**). The “1” position provides dim illumination while the “2” position provides brighter illumination. Typically the dimmer setting is used under dark skies and the brighter setting is used under light-polluted skies or in daylight. Position your eye at a comfortable distance from the rear of the unit. Look through the rear of the finder scope with both eyes open to see the illuminated red dot. The target object should appear in the field of view somewhere near the red dot.

4. You'll want to center the target object on the red dot. To do so, without moving the telescope, use the finder scope's vertical and horizontal adjustment knobs (shown in **Figure 18**) to position the red dot on the object.
5. When the red dot is centered on the distant object, check to make sure the object is still centered in the telescope's eyepiece. If it isn't, re-center it then adjust the finder

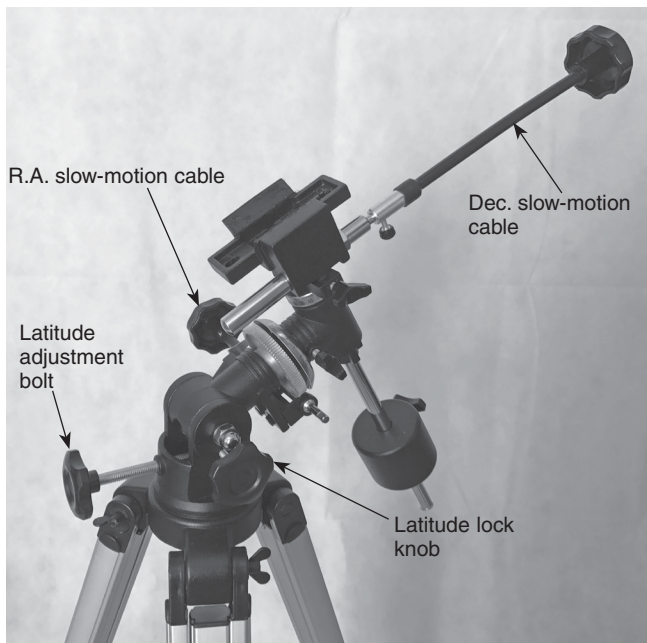

**Figure 11.** The assembled equatorial mount, showing placement of the slow-motion cables.

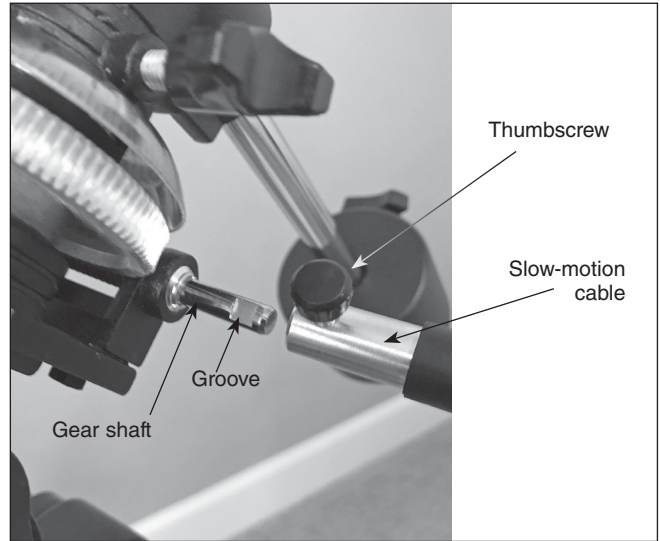

**Figure 12.** Line up the slow-motion cable thumbscrew with the groove in the gear shaft, then tighten.

scope's alignment again. When the object is centered in the telescope eyepiece and on the finder scope's red dot, the finder scope is properly aligned with the telescope. The red dot finder scope's alignment should be checked before every observing session.

At the end of your observing session, be sure to slide the power switch on the red dot finder scope to OFF to preserve battery life.

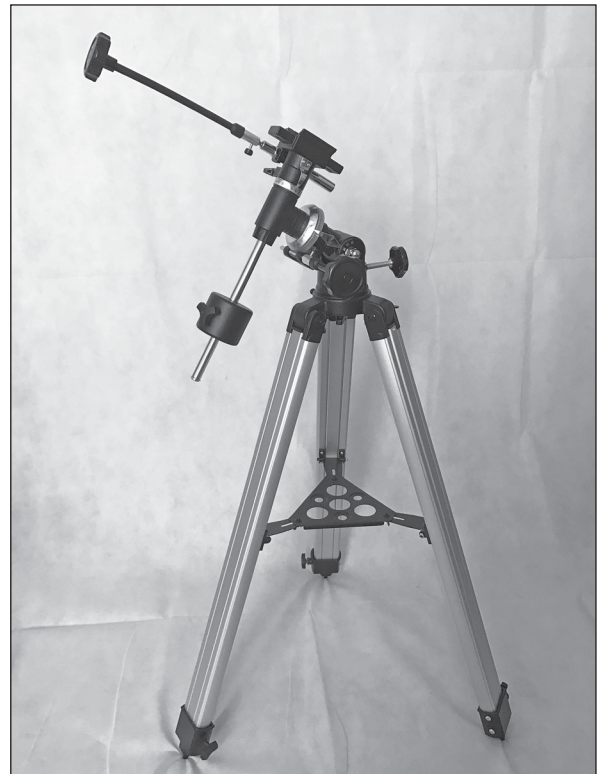

**Figure 13.** The fully assembled equatorial mount and tripod.

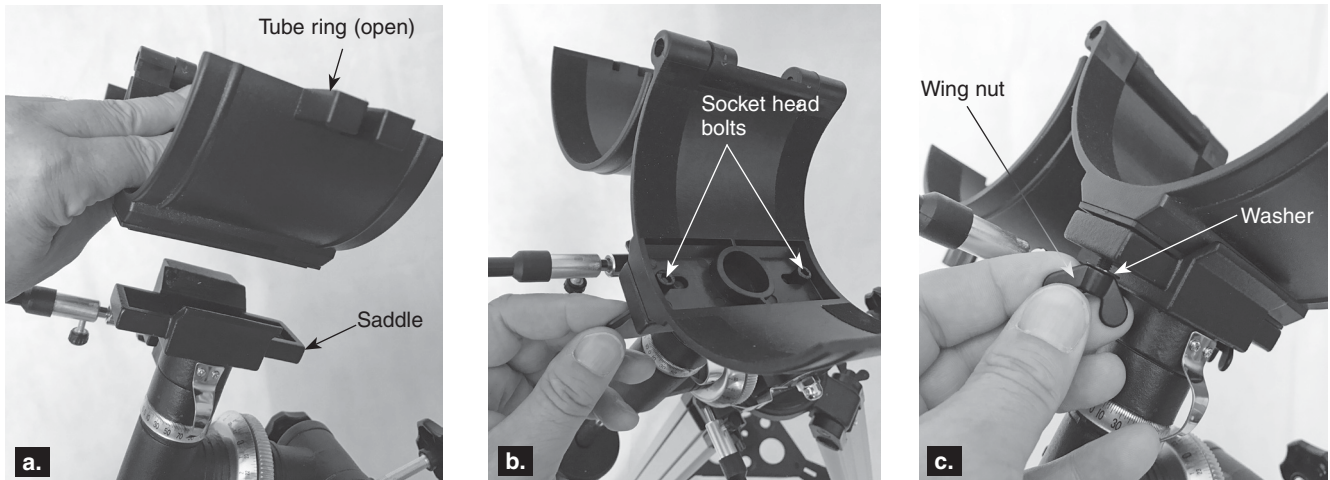

**Figure 14.** Installing the tube ring onto the equatorial mount. **a)** Place open ring in saddle. **b)** Insert socket head screws through aligned holes in ring and saddle, then **c)** place a washer onto the screw followed by a wing nut. Then tighten wing nut.

### Balancing the Telescope

In order for the telescope to move smoothly on its mechanical axes, the optical tube must first be balanced on the mount as follows:

1. Keeping one hand on the telescope optical tube, loosen the R.A. lock knob. Make sure the Dec. lock knob is locked, for now. The telescope should now be able to rotate freely about the R.A. axis. Rotate it until the counterweight shaft is parallel to the ground, i.e., horizontal (**Figure 20a**).

2. Now loosen the counterweight lock knob and slide the weight along the shaft until it exactly counterbalances the telescope. That's the point at which the shaft remains horizontal even when you let go of the telescope with both hands.
3. Retighten the counterweight lock knob. The telescope is now balanced on the R.A. axis.
4. To balance the telescope on the Dec. axis, first tighten the R.A. lock knob, with the counterweight shaft still in the horizontal position.
5. With one hand on the telescope optical tube, loosen the Dec. lock knob. The telescope should now be able to rotate freely about the Dec. axis (**Figure 20b**). Loosen the tube

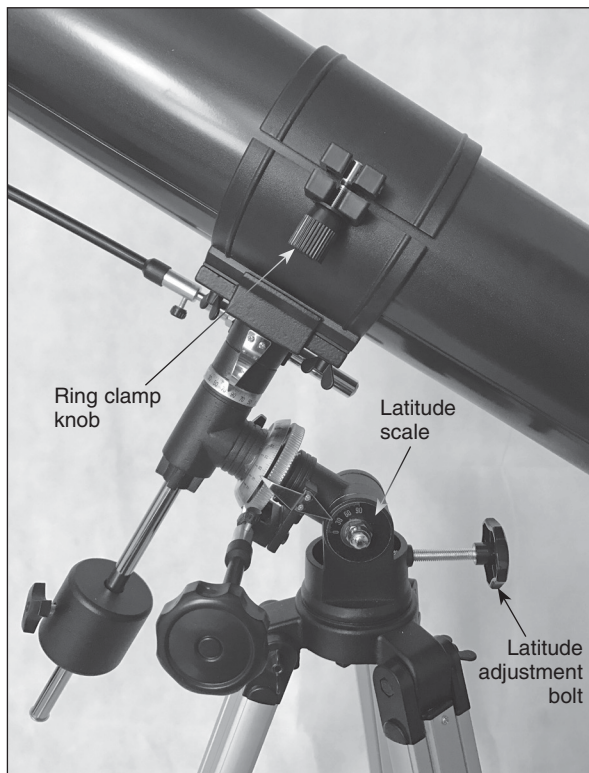

**Figure 15.** Lay the optical tube in the open tube ring, then close the ring and clamp it with the tube ring clamp knob.

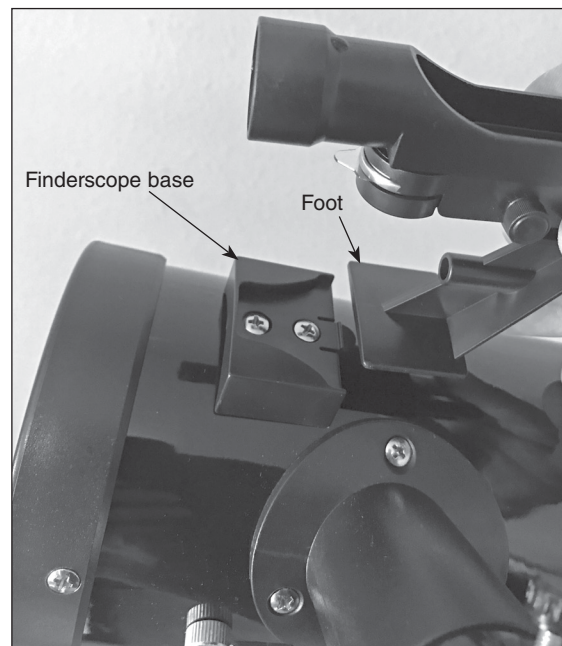

**Figure 16.** Insert the red dot finder scope's bracket foot into the base near the focuser as shown.



**Figure 17.** Eyepiece is shown installed in the focuser.

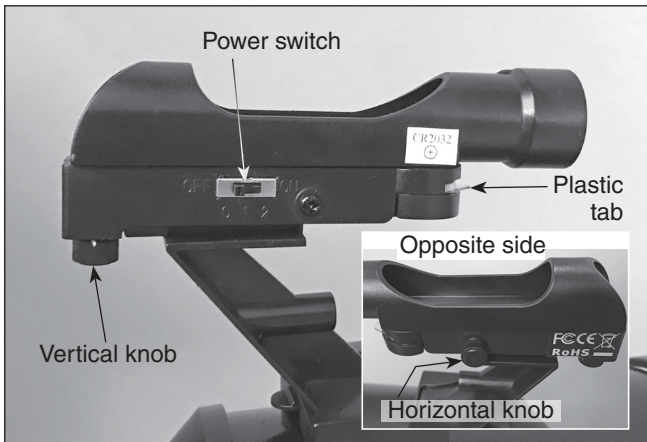

**Figure 18.** The red dot finder scope has vertical and (inset) horizontal adjustment knobs for aligning it with the telescope.

ring clamp knob a few turns, until you can slide the telescope tube forward and back inside the ring. Using a slight twisting motion on the optical tube can help move the tube within the ring.

6. Position the telescope so it remains horizontal when you carefully let go with both hands. This is the balance point. Before clamping the tube ring tight again, rotate the telescope so the eyepiece is at a convenient angle for viewing. When you are actually observing with the telescope, you can adjust the eyepiece position by loosening the tube ring and rotating the optical tube.
7. Retighten the tube ring clamp knobs.

The telescope is now balanced on both axes. Now when you

loosen the lock knob on one or both axes and manually point the telescope, it should move without resistance and should not drift from where you point it.

## 4. Understanding and Using the Equatorial Mount

When you look at the night sky, you no doubt have noticed the stars appear to move slowly from east to west over time. That apparent motion is caused by the Earth's rotation (from west to east). An equatorial mount is designed to compensate for that motion, allowing you to easily "track" the movement of astronomical objects, thereby keeping them from drifting out of the telescope's field of view while you're observing.

This is accomplished by slowly rotating the telescope on its right ascension (R.A.) axis, using only the R.A. slow-motion cable. But first the R.A. axis of the mount must be aligned with the Earth's rotational (polar) axis—a process called polar alignment.

### Polar Alignment

For Northern Hemisphere observers, approximate polar alignment is achieved by pointing the mount's right ascension axis at the North Star (Polaris). It lies within  $1^\circ$  of the north celestial pole (NCP), which is an extension of the Earth's rotational

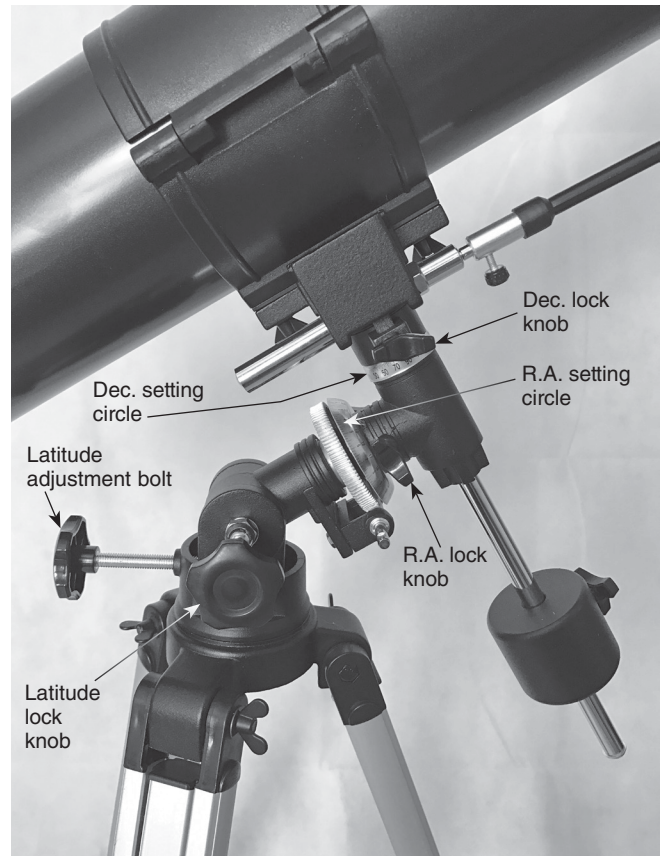

**Figure 19.** Get to know the knobs and setting circles on the equatorial mount.



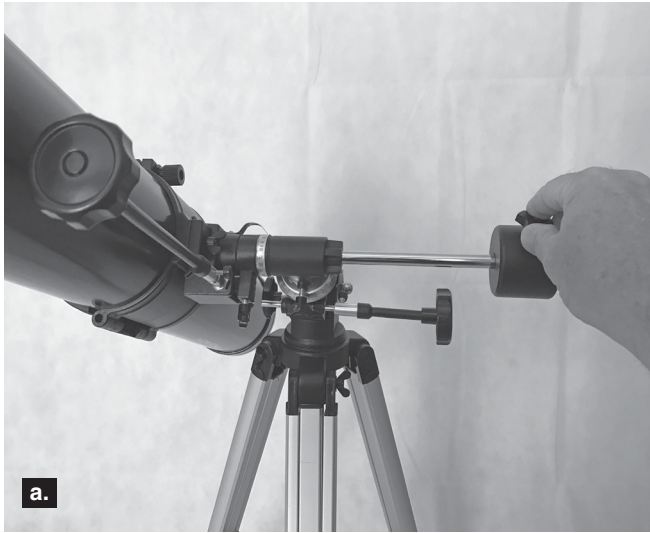
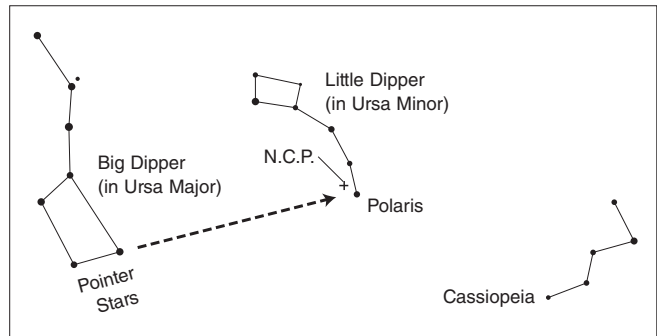

**Figure 20.** Balancing the telescope about the **a)** R.A. and **b)** Dec. axes.

axis out into space. Stars in the Northern Hemisphere appear to revolve around the NCP.

To find Polaris in the sky, look north and locate the pattern of the Big Dipper (**Figure 21**). The two stars at the end of the “bowl” of the Big Dipper point approximately to Polaris.

Observers in the Southern Hemisphere aren’t so fortunate to have a bright star so near the south celestial pole (SCP). The



**Figure 21.** To find Polaris in the night sky, look north and find the Big Dipper. Extend an imaginary line from the two “Pointer Stars” in the bowl of the Big Dipper. Go about five times the distance between those stars and you’ll reach Polaris, which lies within  $1^\circ$  of the north celestial pole (NCP).

star Sigma Octantis lies about  $1^\circ$  from the SCP, but it is barely visible with the naked eye (magnitude 5.5).

To polar align the equatorial mount:

1. Roughly level the equatorial mount by adjusting the length of the three tripod legs as needed.
2. Loosen the latitude lock knob (see **Figure 19**). Turn the latitude adjustment bolt until the pointer on the latitude scale is indicating the latitude of your observing location (**Figure 15**). If you don’t know your latitude, you can look it up on the internet. For example, if your latitude is  $35^\circ$  North, set the pointer to 35. Then retighten the latitude lock knob. The latitude setting should not have to be adjusted again unless you move to a different viewing location some distance away.
3. Loosen the Dec. lock knob and rotate the telescope optical tube until it is parallel with the R.A. axis, as it is in **Figure 2**. The pointer on the Dec. setting circle should read  $90^\circ$ . Retighten the Dec. lock knob.
4. Loosen the azimuth lock knob at the base of the equatorial mount (**Figure 7b**) a half turn or so and rotate the mount so the R.A. axis points roughly at Polaris. If you cannot see Polaris directly from your observing site, consult a compass and rotate the mount so the telescope points North. Retighten the azimuth lock knob.

The equatorial mount is now polar aligned. **From this point on in your observing session, you should not make any further adjustments to the azimuth or the latitude of the mount, nor should you move the tripod.** Doing so will undo the polar alignment. The telescope should be moved only about its R.A. and Dec. axes.

### Using the R.A. and Dec. Slow-Motion Control Cables

The R.A. and Dec. slow-motion control cables allow fine adjustment of the telescope’s position to center objects within the field of view. Before using the cables, manually “slew” the mount to point the telescope in the vicinity of the desired target. Do this by loosening the R.A. and Dec. lock knobs (**Figure 19**) and moving the telescope about the mount’s R.A. and Dec.

---

axes. Once the telescope is pointed somewhere close to the object to be viewed, retighten the mount's R.A. and Dec. lock knobs.

The object should now be visible somewhere in the field of view of the red dot finder scope. If it isn't, use the slow-motion controls to scan the surrounding area of sky. **Note: when using the slow motion cables, the R.A. and Dec lock knobs should be tightened, not loose.** When the object is visible in the finder scope, use the slow-motion controls to center the red dot on it. Now, look in the telescope's eyepiece and use the slow-motion controls to center it in the eyepiece.

The Dec. slow-motion control cable can move the telescope a maximum of 25° or so. This is because the Dec. slow-motion mechanism has a limited range of mechanical travel. (The R.A. slow-motion mechanism has no limit to its amount of travel.) If you can no longer rotate the Dec. control cable in a desired direction, you have reached the end of travel, and the slow-motion mechanism must be reset. This is done by first rotating the control cable several turns in the opposite direction from which it was being turned. Then, manually slew the telescope closer to the object you wish to observe (remember to first loosen the Dec. lock knob). You should now be able to use the Dec. slow-motion control cable again to fine adjust the telescope's position.

### Tracking Celestial Objects

When you observe a celestial object through the telescope, you'll see it drift slowly across the field of view. To keep it in the field, assuming your equatorial mount is polar aligned, just turn the R.A. slow-motion control cable clockwise, if the slow-motion cable is mounted on the EAST side of the mount. If it's on the WEST side of the mount, turn it counterclockwise to track. The Dec. slow-motion control cable is not needed for tracking. Objects will appear to move faster at higher magnifications, because the field of view is narrower.

### Optional Electronic Drive for Automatic Tracking

An optional DC electronic drive can be mounted on the R.A. axis of the equatorial mount to provide hands-free tracking. Objects will then remain stationary in the field of view without any manual adjustment of the R.A. slow-motion control cable.

### Understanding the Setting Circles

The two setting circles (**Figure 19**) on an equatorial mount enable you to locate celestial objects by their "celestial coordinates." Every object resides in a specific location on the "celestial sphere." That location is denoted by two numbers: its right ascension (R.A.) and declination (Dec.). In the same way, every location on Earth can be described by its longitude and latitude. R.A. is similar to longitude on Earth, and Dec. is similar to latitude. The R.A. and Dec. values for celestial objects can be found in any star atlas or star catalog.

The mount's R.A. setting circle is scaled in hours, from 1 through 24, with small marks in between representing 10-minute increments. The numbers closest to the R.A. axis gear apply to viewing in the Southern Hemisphere, while the numbers above them apply to viewing in the Northern Hemisphere.

The Dec. setting circle is scaled in degrees, with each mark representing 2.5° increments. Values of Dec. coordinates range from +90° to -90°. The 0° mark indicates the celestial equator. When the telescope is pointed north of the celestial equator, values of the Dec. setting circle are positive, while when the telescope is pointed south of the celestial equator, values of the Dec. setting circle are negative.

So, the coordinates for the Orion Nebula are:

R.A. 5h 35.4m Dec. -5° 27'

That's 5 hours and 35.4 minutes in right ascension, and -5 degrees and 27 arc-minutes in declination (there are 60 arc-minutes in 1 degree of declination).

Before you can use the setting circles to locate objects, the mount must be properly polar aligned, and the R.A. setting circle must be calibrated. The Dec. setting circle has been permanently calibrated at the factory, and should read 90° whenever the telescope optical tube is parallel with the R.A. axis.

### Calibrating the Right Ascension Setting Circle

Identify a bright star in the sky near the celestial equator (Dec. = 0°) and look up its coordinates in a star atlas.

1. Loosen the R.A. and Dec. lock knobs on the equatorial mount, so the telescope optical tube can move freely.
2. Point the telescope at the bright star whose coordinates you know. Lock the R.A. and Dec. lock knobs. Center the star in the telescope's field of view with the slow-motion control cables.
3. Rotate the setting circle until the metal arrow indicates the R.A. coordinate listed in the star atlas for the object.

### Finding Objects with the Setting Circles

1. Now that both setting circles are calibrated, look up in a star atlas the coordinates of an object you wish to view.
2. Loosen the R.A. lock knob and rotate the telescope until the R.A. value from the star atlas matches the reading on the R.A. setting circle. Remember to use the upper set of numbers on the R.A. setting circle. Retighten the lock knob.
3. Loosen the Dec. lock knob and rotate the telescope until the Dec. value from the star atlas matches the reading on the Dec. setting circle. Remember that values of the Dec. setting circle are positive when the telescope is pointing north of the celestial equator (Dec. = 0°), and negative when the telescope is pointing south of the celestial equator. Retighten the lock knob.

Most setting circles are not accurate enough to put an object dead-center in the telescope's eyepiece, but they should place the object somewhere within the field of view of the red dot finder scope, assuming the equatorial mount is accurately polar aligned. Use the slow-motion controls to center the object in the finder scope, and it should appear in the telescope's field of view.

The R.A. setting circle must be re-calibrated every time you wish to locate a new object. Do so by calibrating the setting circle for the centered object before moving on to the next one.

---

### Confused About Pointing the Telescope?

Beginners occasionally experience some confusion about how to point the telescope overhead or in other directions. One thing you DO NOT do is make any adjustment to the mount's latitude setting or to its azimuth position (don't touch the azimuth lock knob). That will throw off the mount's polar alignment. Once the mount is polar aligned, the telescope should be moved only about the R.A. and Dec. axes by loosening one or both of the R.A. and Dec. lock knobs and moving the telescope by hand, or keeping the knobs tightened and moving the telescope using the slow-motion cables.

## 5. Astronomical Observing

For many, this will be your first foray into the exciting world of amateur astronomy. The following information and observing tips will help get you started.

### Choosing an Observing Site

When selecting a location for observing, get as far away as possible from direct artificial light such as street lights, porch lights, and automobile headlights. The glare from these lights will greatly impair your dark-adapted night vision. Set up on a grass or dirt surface, not asphalt, because asphalt radiates more heat. Heat disturbs the surrounding air and degrades the images seen through the telescope. Avoid viewing over rooftops and chimneys, as they often have warm air currents rising from them. Similarly, avoid observing from indoors through an open (or closed) window, because the temperature difference between the indoor and outdoor air will cause image blurring and distortion.

If at all possible, escape the light-polluted city sky and head for darker country skies. You'll be amazed at how many more stars and deep-sky objects are visible in a dark sky!

### "Seeing" and Transparency

Atmospheric conditions vary significantly from night to night. "Seeing" refers to the steadiness of the Earth's atmosphere at a given time. In conditions of poor seeing, atmospheric turbulence causes objects viewed through the telescope to "boil." If you look up at the sky and stars are twinkling noticeably, the seeing is poor and you will be limited to viewing at lower magnifications. At higher magnifications, images will not focus clearly. Fine details on the planets and Moon will likely not be visible.

In conditions of good seeing, star twinkling is minimal and images appear steady in the eyepiece. Seeing is best overhead, worst at the horizon. Also, seeing generally gets better after midnight, when much of the heat absorbed by the Earth during the day has radiated off into space.

Especially important for observing faint objects is good "transparency"—air free of moisture, smoke, and dust. All tend to scatter light, which reduces an object's brightness. Transparency is judged by the magnitude of the faintest stars you can see with the unaided eye (5th or 6th magnitude is desirable).

### Cooling the Telescope

All optical instruments need time to reach "thermal equilibrium." The bigger the instrument and the larger the temperature change, the more time is needed. Allow at least 30 minutes for your telescope to acclimate to the temperature outdoors before you start observing with it.

### Let Your Eyes Dark-Adapt

Don't expect to go from a lighted house into the darkness of the outdoors at night and immediately see faint nebulas, galaxies, and star clusters—or even very many stars, for that matter. Your eyes take about 30 minutes to reach perhaps 80% of their full dark-adapted sensitivity. As your eyes become dark-adapted, more stars will glimmer into view and you'll be able to see fainter details in objects you view in your telescope.

To see what you're doing in the darkness, use a red-filtered flashlight rather than a white light. Red light does not spoil your eyes' dark adaptation like white light does. A flashlight with a red LED light is ideal. Beware, too, that nearby porch, streetlights, and car headlights will ruin your night vision.

### Eyepiece Selection

Magnification, or power, is determined by the focal length of the telescope and the focal length of the eyepiece being used. Therefore, by using eyepieces of different focal lengths, the resultant magnification can be varied. It is quite common for an observer to own five or more eyepieces to access a wide range of magnifications. This allows the observer to choose the best eyepiece to use depending on the object being viewed and viewing conditions. Your SpaceProbe II 76mm EQ comes with 25mm (W) and 10mm (X) Kellner eyepieces, which will suffice nicely to begin with. You can purchase additional eyepieces later if you wish to have more magnification options.

Magnification is calculated as follows:

$$\frac{\text{Telescope Focal Length (mm)}}{\text{Eyepiece Focal Length (mm)}} = \text{Magnification}$$

For example, the SpaceProbe II 76mm EQ has a focal length of 700mm, which when used with the supplied 25mm eyepiece yields:

$$\frac{700 \text{ mm}}{25 \text{ mm}} = 28x$$

The magnification provided by the 10mm eyepiece is:

$$\frac{700 \text{ mm}}{10 \text{ mm}} = 70x$$

The maximum attainable magnification for a telescope is directly related to how much light it can gather. The larger the aperture, the more magnification is possible. In general, a figure of 50x per inch of aperture is the maximum attainable for most telescopes. Going beyond that will yield simply blurry, unsatisfactory views. Your SpaceProbe II 76mm EQ has an aperture of 76mm, or 3.0 inches, so the maximum magnification would be about 150x (3.0 x 50). This level of magnification assumes you have ideal atmospheric conditions for observing (which is seldom the case).

---

Keep in mind that as you increase magnification, the brightness of the object viewed will decrease; this is an inherent principle of the laws of physics and cannot be avoided. If magnification is doubled, an image appears four times dimmer. If magnification is tripled, image brightness is reduced by a factor of nine!

Start by centering the object you wish to see in the 25mm eyepiece. Then you may want to increase the magnification to get a closer view, by switching to the 10mm eyepiece. If the object is off-center (i.e., it is near the edge of the field of view) you will lose it when you increase magnification, since the field of view will be narrower with the higher-powered eyepiece. So make sure it is centered in the 25mm eyepiece before switching to the 10mm eyepiece.

### **Focusing the Telescope**

To focus the telescope, turn the focus wheels (**Figure 17**) forward or back until you see your target object (e.g., stars, the Moon, etc.) in the eyepiece. Then make finer adjustments until the image is sharp. If you're having trouble achieving initial focus, rack the focuser drawtube all the way in using the focus wheels, then while looking into the eyepiece slowly turn the focus wheels so that the drawtube extends outward. Keep going until you see your target object come into focus. Note that when you change eyepieces you may have to adjust the focus a bit to get a sharp image with the newly inserted eyepiece.

### **What to Expect**

So what will you see with your telescope? You should be able to see bands on Jupiter, the rings of Saturn, craters on the Moon, the waxing and waning of Venus, and many bright deep-sky objects. Do not expect to see color as you do in NASA photos, since those are taken with long-exposure cameras and have "false color" added. Our eyes are not sensitive enough to see color in deep-sky objects except in a few of the brightest ones.

### **Objects to Observe**

Now that you are all set up and ready to go, what is there to look at in the night sky?

#### **A. The Moon**

With its rocky surface, the Moon is one of the easiest and most interesting objects to view with your telescope. Lunar craters, maria, and even mountain ranges can all be clearly seen from a distance of 238,000 miles away! With its ever-changing phases, you'll get a new view of the Moon every night. The best time to observe our one and only natural satellite is during a partial phase, that is, when the Moon is not full. During partial phases, shadows are cast on the surface, which reveal more detail, especially right along the border between the dark and light portions of the disk (called the "terminator"). A full Moon is too bright and devoid of surface shadows to yield a pleasing view. Make sure to observe the Moon when it is well above the horizon to get the sharpest images.

Use an optional Moon filter to dim the Moon when it is very bright. It simply threads onto the bottom of the eyepieces (you

must first remove the eyepiece from the focuser to attach a filter). You'll find that the Moon filter improves viewing comfort, and helps to bring out subtle features on the lunar surface.

#### **B. The Planets**

The planets don't stay put like the stars, so to find them you should refer to the monthly star charts at OrionTelescopes.com, or to charts published monthly in *Astronomy*, *Sky & Telescope*, or other astronomy magazines. Venus, Mars, Jupiter, and Saturn are the brightest objects in the sky after the Sun and the Moon. Other planets may be visible but will likely appear star-like. Because planets are quite small in apparent size, optional higher-power eyepieces or a Barlow lens are recommended and often needed for detailed observations.

#### **B. The Sun**

You can change your nighttime telescope into a daytime Sun viewer by installing an optional full-aperture solar filter over the front opening of the telescope. The primary attraction is sunspots, which change shape, appearance, and location daily. Sunspots are directly related to magnetic activity in the Sun. Many observers like to make drawings of sunspots to monitor how the Sun is changing from day to day.

**Important Note:** Do not look at the Sun with any optical instrument without a professionally made solar filter, or permanent eye damage could result.

#### **D. The Stars**

Stars will appear like twinkling points of light. Even powerful telescopes cannot magnify stars to appear as more than a point of light. You can, however, enjoy the different colors of the stars and locate many pretty double and multiple stars. The famous "Double-Double" in the constellation Lyra and the gorgeous two-color double star Albireo in Cygnus are favorites. Defocusing a star slightly can help bring out its color.

#### **E. Deep-Sky Objects**

Under dark skies, you can observe a wealth of fascinating deep-sky objects, including gaseous nebulas, open and globular star clusters, and different types of galaxies. Most deep-sky objects are very faint, so it is important you find an observing site well away from light pollution.

To find deep-sky objects with your telescope, you first need to become reasonably familiar with the night sky. Unless you know how to recognize the constellation Orion, for instance, you won't have much luck locating the Orion Nebula. A simple planisphere, or star wheel, can be a valuable tool for learning the constellations and seeing which ones are visible in the sky on a given night. Once you have identified a few constellations, a good star chart, atlas, or astronomy app will come in handy for helping locate interesting deep-sky objects to view within the constellations.

Do not expect these objects to appear like the photographs you see in books and on the internet; most will look like dim gray smudges. Our eyes are not sensitive enough to see color in deep-sky objects except in a few of the brightest ones. But as you become more experienced and your observing skills get sharper, you will be able to ferret out more and more subtle details and structure.

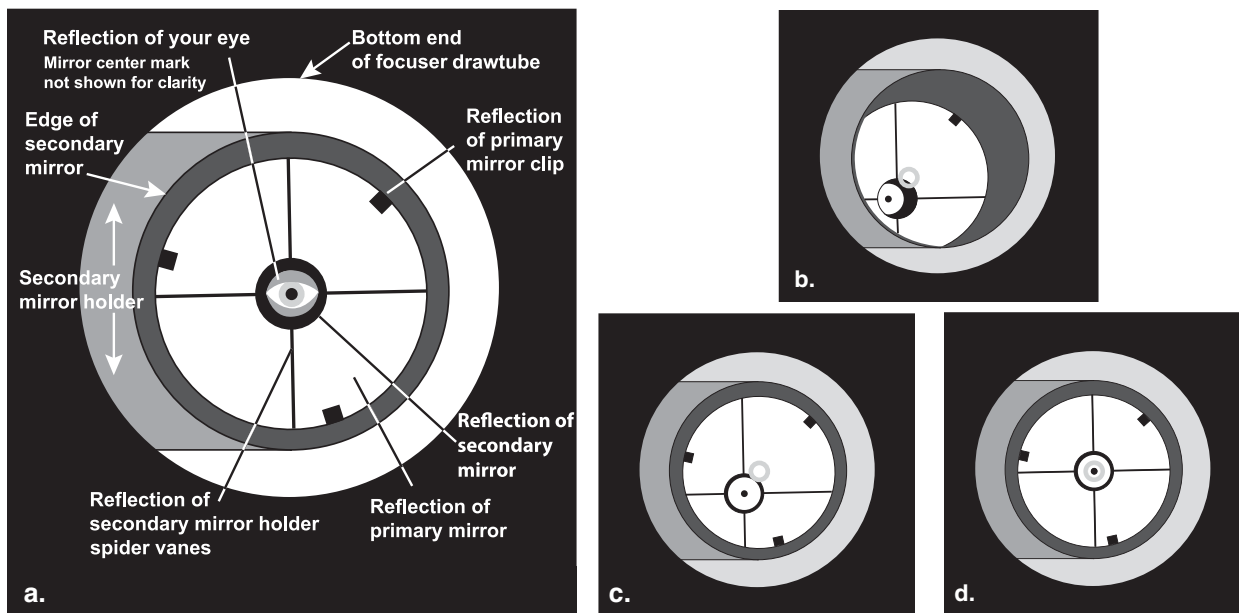

**Figure 22.** Collimating the optics. **a)** When the mirrors are properly aligned, the view down the focuser drawtube should look like this. **b)** If the optics are out of alignment, the view might look something like this (with a collimation cap or Cheshire eyepiece in place). Here, only part of the primary mirror is visible in the secondary mirror, so the secondary mirror needs to be adjusted (tilted). **c)** Here the secondary mirror is correctly aligned because the entire primary mirror is visible in it. But the reflection of the secondary mirror is off-center. So the primary mirror still needs adjustment. **d)** Now the primary mirror is correctly aligned, so the secondary mirror is centered.

## 6. Useful Optional Accessories

- **Moon Filter** – A 1.25" Moon filter will cut down the strong glare of sunlight reflected from the Moon, making Moon viewing more comfortable and revealing more surface detail. The filter threads into the bottom of the Kellner eyepieces that came with your telescope (**Figure 26**).
- **Motor Drive** – A motor drive, which attaches to the right ascension axis of an equatorial telescope mount, enables your telescope to “track” the motion of stars and other celestial objects as they drift slowly from east to west in the night sky. This keeps them in the eyepiece field of view indefinitely, instead of drifting out of sight.
- **Barlow Lens** – A 2x Barlow lens doubles the magnifying power of any eyepiece it’s used with, giving you a big power boost to get in closer to your target object. You just insert it between the diagonal and the eyepiece.
- **Planisphere** – A nifty “star wheel” that shows what stars and constellations are visible in the sky at any time of any night. Just set the date and time see a mini representation of your local night sky. Great for identifying what you see and planning an evening’s observing session.
- **Star Map** – More detailed than a planisphere, a star map is essential for locating interesting celestial objects to observe with your telescope. Nowadays many mobile astronomy apps feature customizable star maps that you can access on your smartphone or tablet while you’re at the telescope.

## 7. Aligning the Mirrors (Collimation)

Collimation is the process of adjusting the optics of a telescope so they are precisely aligned with one another and with the telescope tube. For this reflector telescope, the primary and secondary mirrors must be in precise alignment. Your telescope’s optics were aligned at the factory, and should not need much or any adjustment unless the telescope is handled roughly. Accurate mirror alignment is important to ensure the peak performance of your telescope, so it should be checked occasionally. With practice, collimating is relatively easy to do and can be done in daylight.

It helps to perform the collimation procedure in a brightly lit room with the telescope pointed toward a bright surface, such as a light-colored wall. Placing a piece of white paper in the telescope tube opposite the focuser (i.e., on the other side of the secondary mirror from the focuser) will also be helpful. You will need a Phillips screwdriver to adjust the mirrors.

To check your telescope’s collimation, remove the eyepiece and look down the focuser. You should see the secondary mirror centered in the focuser, as well as the reflection of the primary mirror centered in the secondary mirror, and the reflection of the secondary mirror (and your eye) centered in the reflection of the primary mirror, as in **Figure 22a**. Got all that? Review it again carefully, and compare what you see to **Figure 22a**. If anything is off-center, proceed with the following collimation procedure.

**NOTE:** Precise collimation is best achieved by using an optional collimating tool, such as a quick-collimation cap, a Cheshire eyepiece, or a laser collimator. Check our website for available collimating tools. **Figures 22b through 22d** assume that you have an optional Cheshire eyepiece or collimation cap in the focuser.

### Primary Mirror Center Mark

You may have noticed that your SpaceProbe II 76mm reflector has a tiny ring (sticker) in the exact center of the primary mirror. This “center mark” allows you to achieve a very precise collimation of the primary mirror; you don’t have to guess where the center of the mirror is, which is important in the collimation process. This center mark is especially useful when using an optional collimating device, such as Orion’s LaserMate Deluxe II laser collimator.

**NOTE:** The center ring sticker should not be removed from the primary mirror. Because it lies directly in the shadow of the secondary mirror, its presence in no way adversely affects the optical performance of the telescope or the image quality. That might seem counter-intuitive, but it’s true! Leave it in place.

### Aligning the Secondary Mirror

Align the secondary mirror first. Look down the focuser at the secondary (diagonal) mirror. If the entire primary mirror reflection is not visible in the secondary mirror, as in **Figure 22b**, you will need to adjust the tilt of the secondary mirror. This is done by alternately loosening one of the three

secondary mirror alignment screws with a Phillips screwdriver then tightening the other two (**Figure 23**). The goal is to center the primary mirror reflection in the secondary mirror, as in **Figure 22c**. Don’t worry that the reflection of the secondary mirror (the smallest circle) is off-center. You will fix that in the next step. It will take some trial and error to determine which screws to loosen and tighten to move the reflection of

the primary mirror to the center of the secondary mirror. But be patient and you’ll get it.

### Aligning the Primary Mirror

The final adjustment is made to the primary mirror. It will need adjustment if, as in **Figure 22c**, the reflection of the primary mirror is centered in the secondary mirror, but the small reflection of the secondary mirror is off-center. The tilt of the primary mirror is adjusted using the three pairs of collimation screws on the back end of the optical tube (**Figure 24**). Adjusting the tilt of the mirror requires a “push-pull” technique involving adjustment of one or more pairs of collimation screws.

With a Phillips screwdriver, loosen one of the screws one full turn, and then tighten the adjacent screw (the one right next to it) until it is tight. Look into the focuser and see if the secondary mirror reflection has moved closer to the center of the primary. You can tell this easily by simply watching to see if the “dot” of the Cheshire eyepiece or collimation cap is moving closer or farther away from the ring on the center of the primary mirror. Repeat this process on the other two sets of collimation screws, if necessary. Again, it will take a little trial and error to get a feel for how to tilt the mirror in this way.

When you have the dot centered as much as possible in the ring, your primary mirror is collimated. The view through the collimation cap should resemble **Figure 22d**. Make sure all the collimation screws are tight (but do not overtighten), to secure the mirror tilt. A simple star test will tell you whether the optics are accurately collimated.

### Star-Testing the Telescope

When it is dark, point the telescope at a bright star and accurately center it in the eyepiece’s field of view. Slowly de-focus the image with the focusing knob. If the telescope is correctly collimated, the expanding disk should be a perfect circle (**Figure 25**). If the image is unsymmetrical, the scope is out of collimation. The dark shadow cast by the secondary mir-

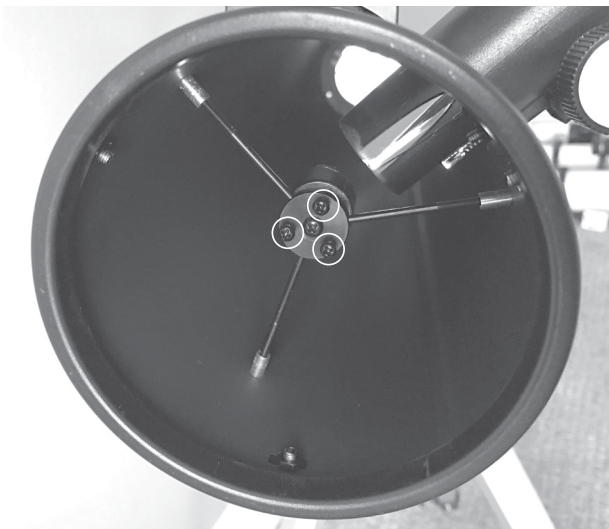
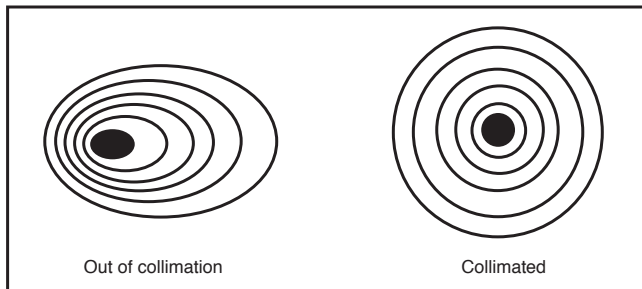

**Figure 23.** Adjust the tilt of the secondary mirror by adjusting the three alignment screws with a Phillips screwdriver.



**Figure 24.** Align the primary mirror by adjusting the three pairs of “push/pull” screws on the back end of the optical tube.

ror should appear in the very center of the out-of-focus circle, like the hole in a donut. If the “hole” appears off-center, the telescope is out of collimation. If you try the star test and the bright star you have selected is not accurately centered in the eyepiece, the optics will always appear out of collimation, even though they may be perfectly aligned. It is critical to keep the star centered, so over time you will need to make slight corrections to the telescope’s position in order to account for the sky’s apparent motion.



**Figure 25.** A star test will determine if the telescope’s optics are properly collimated.



**Figure 26.** The Kellner eyepieces have barrels threaded to accept optional Orion 1.25” filters. A Moon filter is useful for cutting glare and revealing more detail on the lunar surface.

## 8. Telescope Care and Maintenance

If you give your telescope reasonable care, it will last a lifetime. Store it in a clean, dry, dust free place, safe from rapid changes in temperature and humidity. Do not store the telescope outdoors, although storage in a garage or shed is OK. Small components like eyepieces and other accessories should be kept in a protective box or storage case. Keep the caps on the front of the telescope and on the focuser drawtube when not in use.

Your SpaceProbe II 76mm EQ telescope requires very little mechanical maintenance. The optical tube is steel and has a smooth painted finish that is fairly scratch resistant. If a scratch does appear, it will not harm the telescope.

### Cleaning Optics

You should not have to clean the telescope’s mirrors. Covering the telescope with the dust cap when it is not in use will help prevent dust from accumulating on the mirrors. Even a little dust on the mirror surfaces will not affect the optical performance in any way. If you feel the mirrors need to be cleaned, please contact Orion Customer Service at 800-676-1343 for guidance.

To clean the eyepiece lenses, any quality optical lens cleaning tissue and optical lens cleaning fluid specifically designed for multi-coated optics can be used. Never use regular glass cleaner or cleaning fluid designed for eyeglasses. Before cleaning, remove any loose particles or dust from the lens with a blower bulb or soft brush. Then apply some cleaning fluid to a tissue, never directly on the optics. Wipe the lens gently in a circular motion, then remove any excess fluid with a fresh lens tissue. Oily fingerprints and smudges may be removed using this method. Use caution; rubbing too hard may scratch the lens. On larger lenses, clean only a small area at a time, using a fresh lens tissue on each area. Never reuse tissues.

When bringing the telescope inside after an evening’s viewing it is normal for moisture to accumulate on the lenses due to the change in temperature. We suggest leaving the telescope and eyepieces uncovered overnight to allow the condensation to evaporate.

## 9. Specifications

**Optical tube material:** Rolled steel

**Primary mirror diameter:** 76mm (3.0")

**Primary mirror coating:** Aluminum with silicon dioxide (SiO<sub>2</sub>) overcoat

**Secondary mirror minor axis dia.:** 19.9mm

**Focal length:** 700mm

**Focal ratio:** f/9.2

**Focuser:** Rack-and-pinion, accepts 1.25" accessories

**Eyepieces:** 25mm and 10mm Kellner, antireflection coated, 1.25" barrel diameter, threaded for Orion filters

**Eyepiece magnification:** 28x (with 25mm eyepiece) and 70x (with 10mm eyepiece)

**Finder scope:** Red dot finder scope

**Mount:** German equatorial

**Tripod:** Aluminum

**Motor drive:** Optional

**Total instrument weight:** 11 lbs., 11 oz.

---

## One-Year Limited Warranty

This Orion product is warranted against defects in materials or workmanship for a period of one year from the date of purchase. This warranty is for the benefit of the original retail purchaser only. During this warranty period Orion Telescopes & Binoculars will repair or replace, at Orion's option, any warranted instrument that proves to be defective, provided it is returned postage paid. Proof of purchase (such as a copy of the original receipt) is required. This warranty is only valid in the country of purchase.

This warranty does not apply if, in Orion's judgment, the instrument has been abused, mishandled, or modified, nor does it apply to normal wear and tear. This warranty gives you specific legal rights. It is not intended to remove or restrict your other legal rights under applicable local consumer law; your state or national statutory consumer rights governing the sale of consumer goods remain fully applicable.

For further warranty information, please visit [www.OrionTelescopes.com/warranty](http://www.OrionTelescopes.com/warranty).



**Corporate Offices:** 89 Hangar Way, Watsonville CA 95076 - USA  
**Toll Free USA & Canada:** (800) 447-1001  
**International:** +1(831) 763-7000  
**Customer Support:** [support@telescope.com](mailto:support@telescope.com)

*Copyright © 2020 Orion Telescopes & Binoculars. All Rights Reserved. No part of this product instruction or any of its contents may be reproduced, copied, modified or adapted, without the prior written consent of Orion Telescopes & Binoculars.*